

Product Brochure

The most affordable or nothing.

Main category: Industrial robot arm /Collaborative robot arm /
Electric gripper/Intelligent actuator/Automation solutions

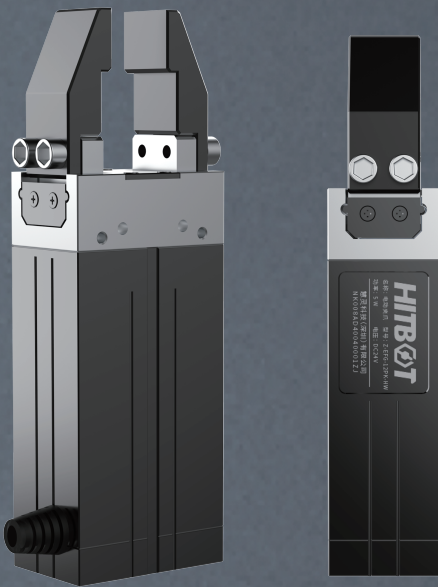

Z-EFG-12

Electric 2-Fingers Parallel Gripper



Product Features

- with servo motor
- The end can be replaced to adapt to various needs
- Pick up fragile and deformable objects such as eggs, test tubes, rings, etc.
- Apply for scenes without air source (e.g. laboratory, hospital)

Promoting a revolution in the replacement of pneumatic grippers by electric grippers

First electric gripper with integrated servo system in China

Highly Integrated

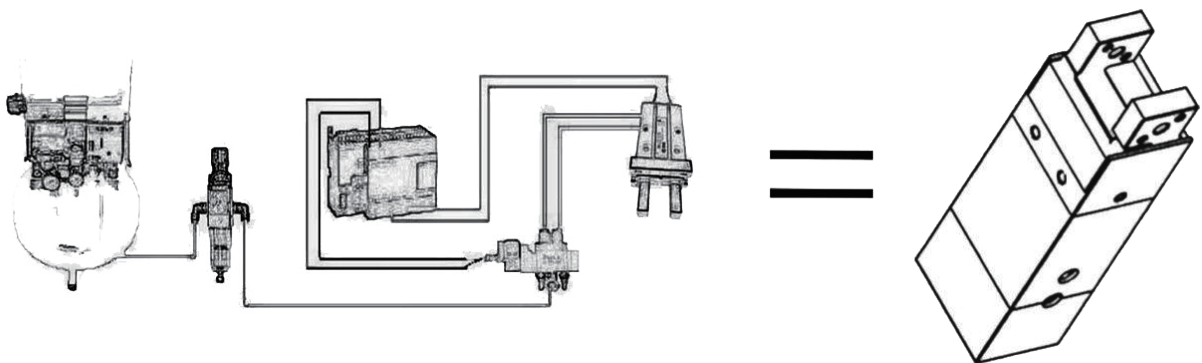

- Perfect replacement for air compressor + filter + solenoid valve + throttle valve + pneumatic gripper
- Multiple cycles service life, consistent with the traditional Japanese cylinder

Application Scenes

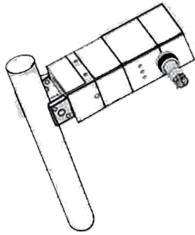

Fragile scene (e.g. test tube)

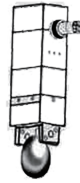

Fragile scene (e.g. eggs)

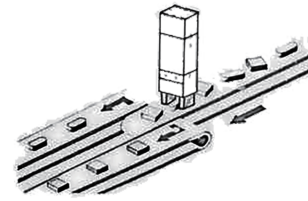

Sorting out things that are arranged in a mess

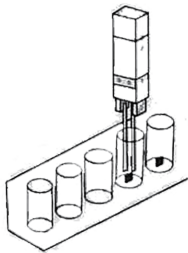

Gripping in narrow scene

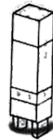

Deformable scene (e.g. rings)



Gripping fragile items at high frequency



Apply for scenes without air source (e.g. laboratory, hospital)

Specification Parameters

Model No. Z-EFG-12	Parameter
Total stroke	12mm
Gripping force	30N
Recommended gripping weight	0.5kg
Transmission mode	Gear rack + Roller ball
Grease replenishment of moving components	Every six months or 1 million movements / time
One-way stroke motion time	0.2s
Operating temperature range	5-55°C
Operating humidity range	RH35-80 (No frost)
Movement mode	Two fingers move horizontally
Stroke control	Non-adjustable
Clamping force adjustment	Non-adjustable
Weight	0.342kg
Dimensions (L*W*H)	48*32*105.6mm
Controller placement	Built-in
Power	5W
Motor type	DC brushless
Rated voltage	24V
Peak Current	1A
Standby current	0.2A

Dimension Installation Diagram

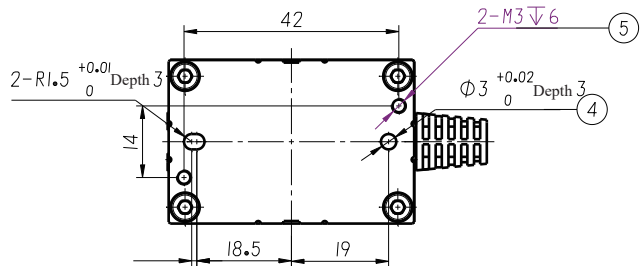
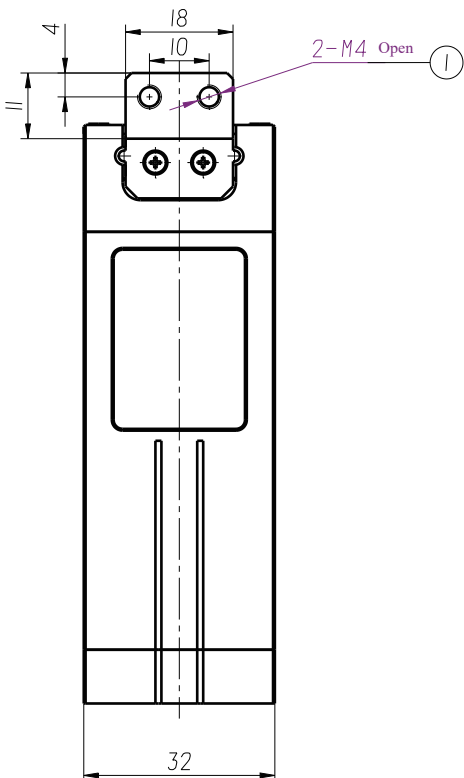
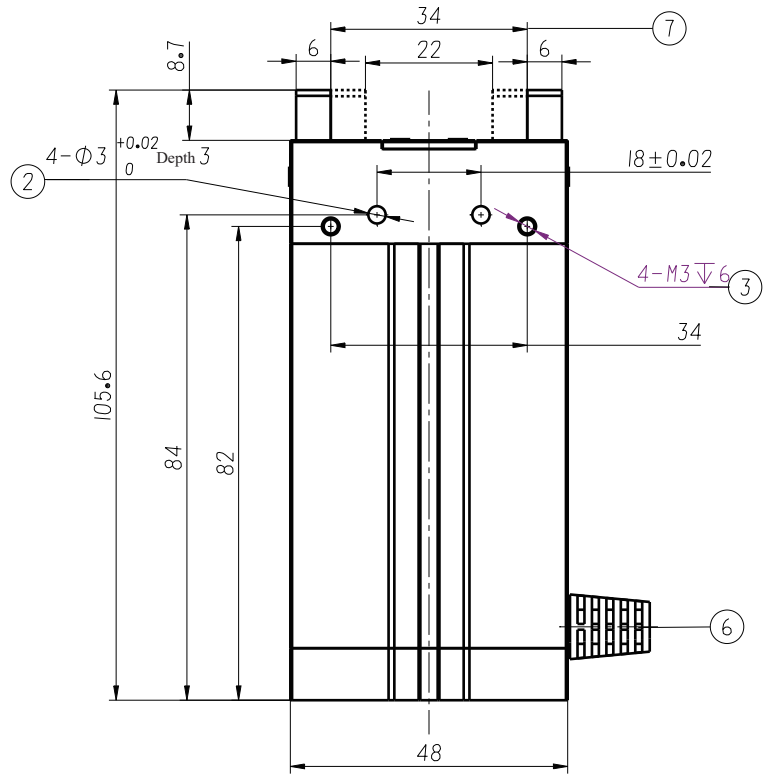
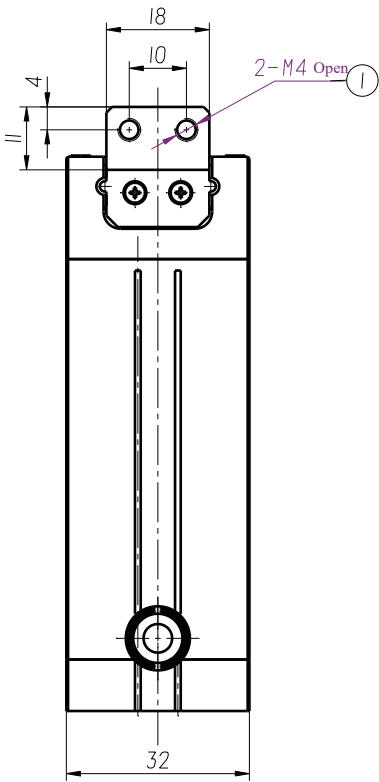

- ① Gripper installation position (threaded hole)
- ② Front mounting position (pin hole)
- ③ Front mounting position (threaded hole)
- ④ Bottom mounting position (pin hole)
- ⑤ Bottom mounting position (threaded hole)
- ⑥ Control cable lead-out position
- ⑦ Movement stroke of gripper fingers

Wire Sequence Description (NPN)

Black Wire	Grey Wire	Function	Description	Remarks
Pink	Red	24V	Power supply	Connected required
Grey	Black	GND	Power supply	Connected required
Orange	Green	Control signal (control clamping)	If the logic level of the controller is 24V, it can be connected directly to the I/O port. The internal is an optocoupler in series to pull up a 2.2K resistor to the internal 24V	Connected required
			If the output is NPN type I/O, it can be directly connected to I/O	
			If the controller output is PNP type, please choose PNP type gripper	
White	White	Control signal (control loosening)	Same as control clamping	Connected required
Yellow	Yellow	Signal output	<ul style="list-style-type: none"> · Selective connection, read-only and display the status of LED · Output open when motion ends. Output 0V or 24V optional when in motion 	Selective connection

Wire Sequence Description (PNP)

Black Wire	Grey Wire	Function	Description	Remarks
Pink	Red	24V	Power supply	Connected required
Grey	Black	GND	Power supply	Connected required
Orange	Green	Control signal (control clamping)	If the logic level of the controller is 24V, it can be connected directly to the I/O port. The internal is an optocoupler in series with a 2.2K resistor	Connected required
			If the logic level of the controller is 24V PNP, it can be directly connected to the I/O port	
			If the controller output is NPN type, please choose NPN type gripper	
White	White	Control signal (control loosening)	Same as control clamping	Connected required
Yellow	Yellow	Signal output	<ul style="list-style-type: none"> · Selective connection, read-only and display the status of LED · Output open when motion ends. Output 0V or 24V optional when in motion 	Selective connection

Caution

Among the wires that must be connected are, +24V, GND, Control signal (control clamping), Control signal (control loosening)

Electrical Parameters

- Rated voltage 24±2V
- Current 0.2A
- Peak current 1A

When the control clamping or the control opening are both valid or invalid, the gripper has no action and no force.

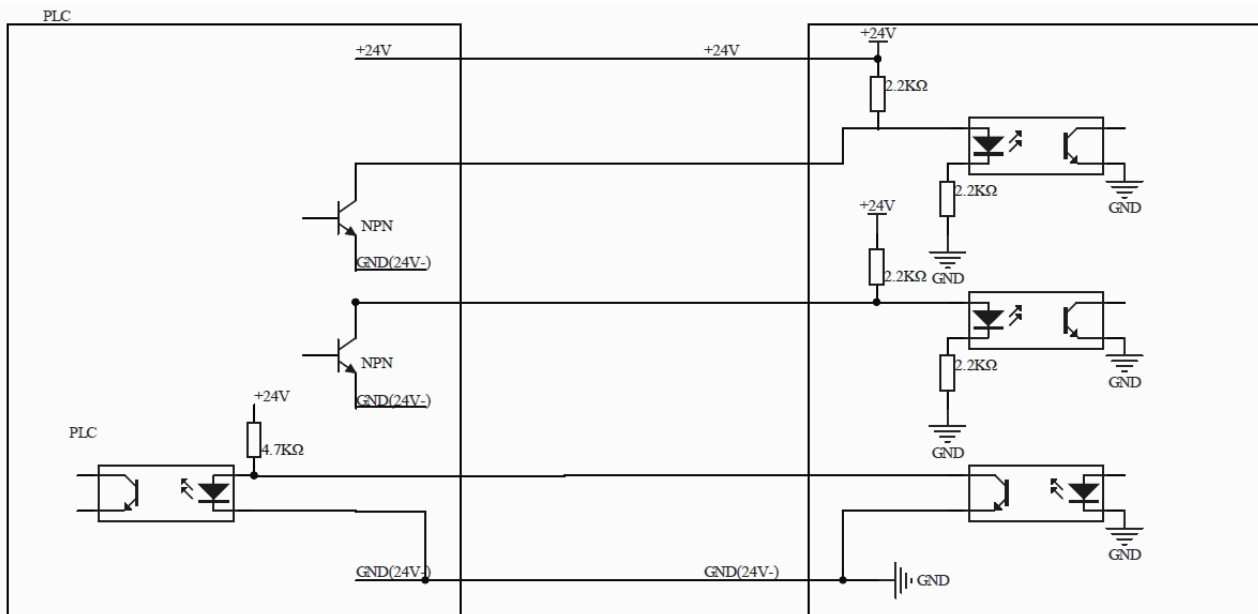

Wiring diagram

Z-EFG-12 Output Wire Physical Diagram

