

Product Specifications

Model	-	Nova 2	Nova 5
Weight	-	11 kg (24.3 lbs)	14 kg (30.9 lbs)
Payload	-	2 kg (4.4 lbs)	5 kg (11 lbs)
Working Radius	-	625 mm (24.6 in)	850 mm (33.5 in)
Maximum Speed	-	1.6 m/s (63 in/s)	2 m/s (78.7 in/s)
Range of Motion	J1	360°	360°
	J2	180°	180°
	J3	156°	160°
	J4 to J6	360°	360°
Maximum Joint Speed	J1 to J6	135° /s	100° /s
End IO	DI	2 inputs	2 inputs
	DO	2 outputs	2 outputs
	RS485	Supported	Supported
Repeatability	-	0.05 mm	0.05 mm
IP Rating	-	IP54	IP54
Noise	-	65 dB (A)	70 dB (A)
Working Environment	-	0° to 50° C (32° to 122° F)	0° to 50° C (32° to 122° F)
Power Consumption	Typical value	100W	230W
	Maximum value	250W	770W
Installation Orientation	-	Any angle	Any angle
Cable Length to Controller	-	3 m (9.84 ft)	3 m (9.84 ft)
Materials	-	Aluminum alloy, ABS plastic	

Product	-	Controller
Dimensions	-	200 mm x 120 mm x 55 mm (7.9 in x 4.7 in x 2.2 in)
Weight	-	1.3 kg (2.9 lbs)
Input Power	-	30 to 60V DC
IO Power	-	24V, Max 2A, Max 0.5A for each channel
IO Interface	DI	8 inputs (NPN or PNP)
	DO	8 outputs (NPN or PNP)
	AI	2 inputs, voltage mode, 0V to 10V
	AO	2 outputs, voltage mode, 0V to 10V
Communication Interface	Network interface	2, for TCP/IP and Modbus TCP communication
	USB	2, for connecting USB wireless module
	485 interface	1, for RS485 and Modbus RTU communication
Working Environment	Temperature	0° to 50° C (32° to 122° F)
	Humidity	0% to 95% noncondensing
Remote Power On/Off	-	Supported
IP Classification	-	IP20
Cooling Mode	-	Passive heat dissipation
Software	-	PC, IOS, Android



DOBOT Nova Series

The Nova series offers clean design aesthetics and is easy to use. Having multiple safety features with customizable colors, Nova is not only safe to work alongside but also fits effortlessly into surroundings. It is ideal to take restaurant, retail shop and physiotherapy experiences to the next level.

Key Features

Peace of Mind

Built in multiple safety features.

Nova is equipped with sensors offering 5 adjustable levels of collision detection. Operation stops in 0.01 second upon detecting collision. Additional safety features such as human motion sensing and posture freeze upon power shutoff realize much desired human-robot collaboration.

Lightweight and Portable

Minimum space. Maximum performance.

Compact joint design results in a light body. Accompanied by a palm-sized control box, Nova occupies just 1 square meter of space. Minimum re-arrangements of store layout are needed.

Easy to Learn and Operate

No prior experience required.

Teach Nova via hand guiding and graphical programming. Simple yet elegant that anyone can master. Training a Nova takes as little time as 10 minutes.

Customization

Create your unique Nova.

Industry first bespoke service on color customization. Take your branding to the next level with your personalized Nova.

Application Scenarios



Nova 2 | For Retail

The Nova 2 is made specifically for retail stores looking for automation. 625 mm working radius and 2 kg payload easily meet the demand of most tasks.

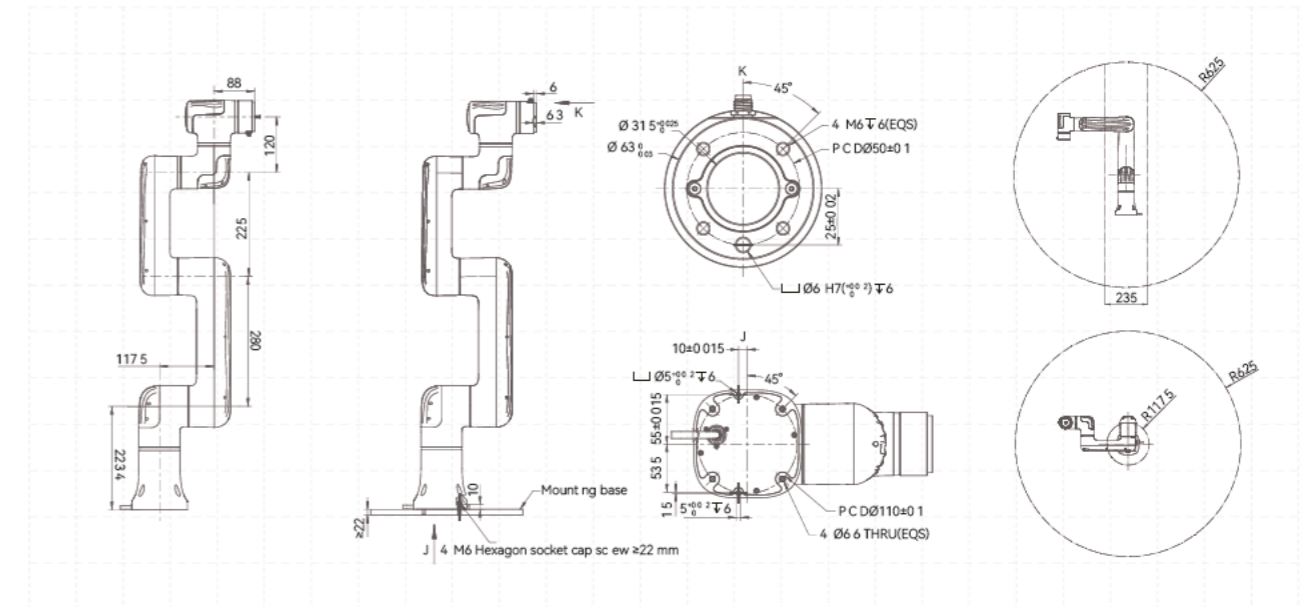

Overall dimension diagram Mounting hole diagram Motion range diagram

Nova 5 | For Physiotherapy

The Nova 5 is made specifically for physiotherapy scenarios. 800 mm working radius easily reaches massage spots like the neck, back and waist.

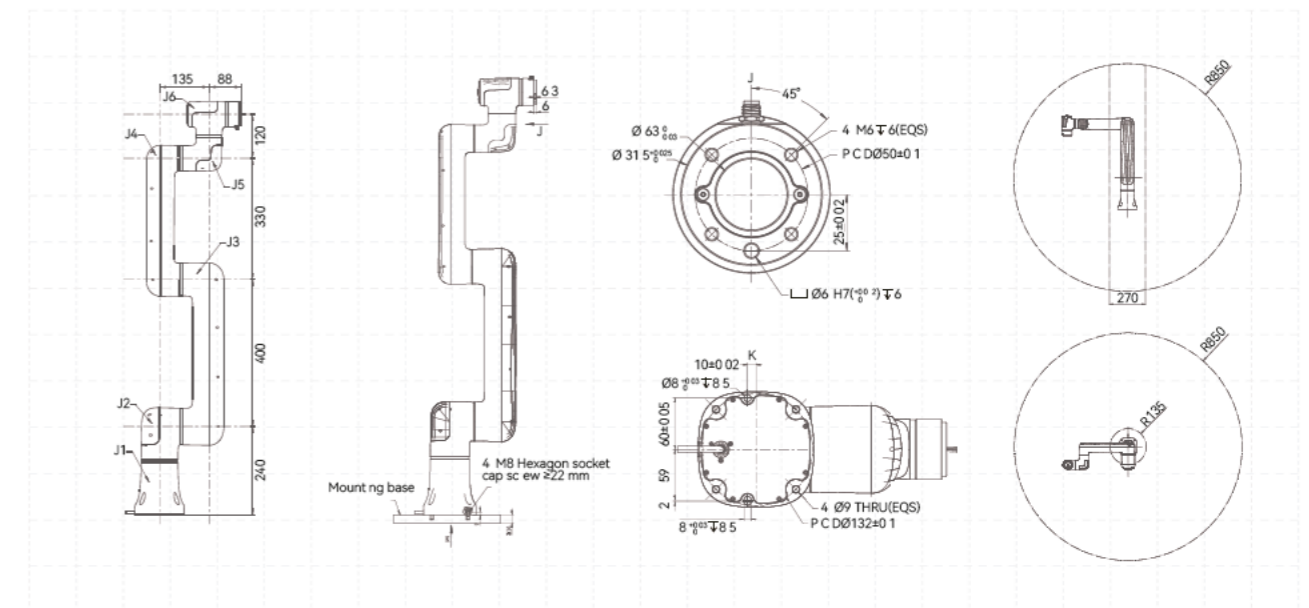

Overall dimension diagram Mounting hole diagram Motion range diagram